

## INSTALLATION MANUAL SCHROTH FRONTAL HEAD RESTRAINT [FHR]

Edition: 01/2020  
Part No: EA 16.3

Thank you for choosing our product.

### OVERVIEW



Read and follow all **WARNINGS**, **CAUTIONS** and **SAFETY INSTRUCTIONS**

## SAFETY INSTRUCTIONS

- \* A FHR is not a substitute for skill or experience. Do not attempt potentially hazardous manoeuvres while wearing a FHR that you would not attempt without a FHR.
- \* FHR is available in medium and large. Sizing is based on body size and shape. Consult your FHR reseller for assistance on determining the correct size.
- \* Failure to ensure that the FHR fits correctly will reduce the effectiveness of the FHR and may subject the user to unexpected risks.
- \* A cracked, bent or deformed FHR or any FHR worn by a user during an accident or impact should not be used again by anyone. Damage affecting the structural integrity and performance of the FHR may not be visible to the naked eye.

The FHR is worn over your shoulders and under your safety harness belts.

The centre line [shown in red] defines the lower tip of the FHR. The shoulder belt length adjusters [shown in green] should rest a maximum of 2.75" [70 mm] above the tips of the FHR or a minimum of 1" [25 mm] below the tips of the FHR.

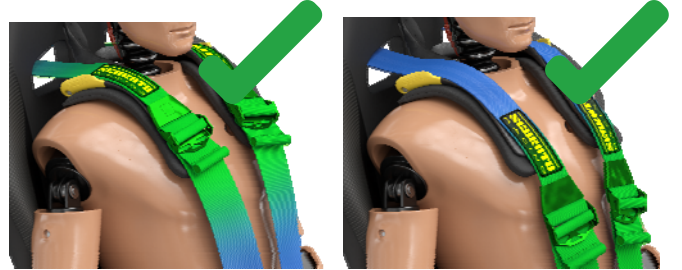
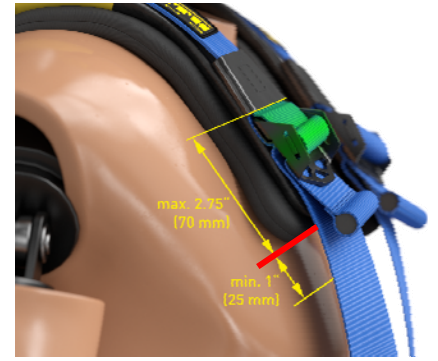

### ! WARNING

Risk of severe injury or death!  
Never modify the hardware, components or body of FHR.  
Any modifications to the FHR may reduce the effectiveness of the product.



Ensure that the tethers are attached to the harness and helmet without twisting. The tethers must be worn in stress direction.

## HEAD REST CLEARANCE

The FHR may lightly contact helmet or head rest when being worn and in use.



## SEAT BELT MOUNTING [FOR DETAILED INFORMATION SEE HARNESS BELT INSTRUCTION AND WWW.SCHROTH.COM/INSTALL]

Shoulder belt mountings located more than 8" [200 mm] from the back of the user's seat or angled upwards can severely compromise the effective performance of the FHR and safety harness. Avoid this type of installation. Never use sternum straps in combination with the FHR.

### SHOULDER BELT ANGLES

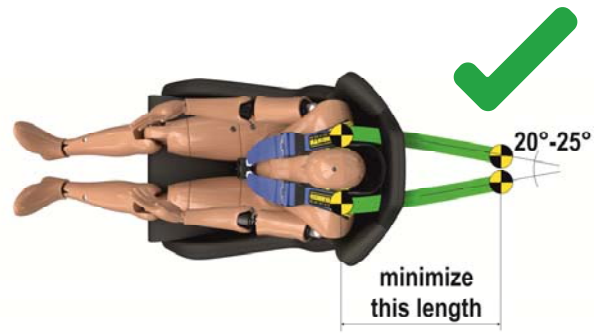
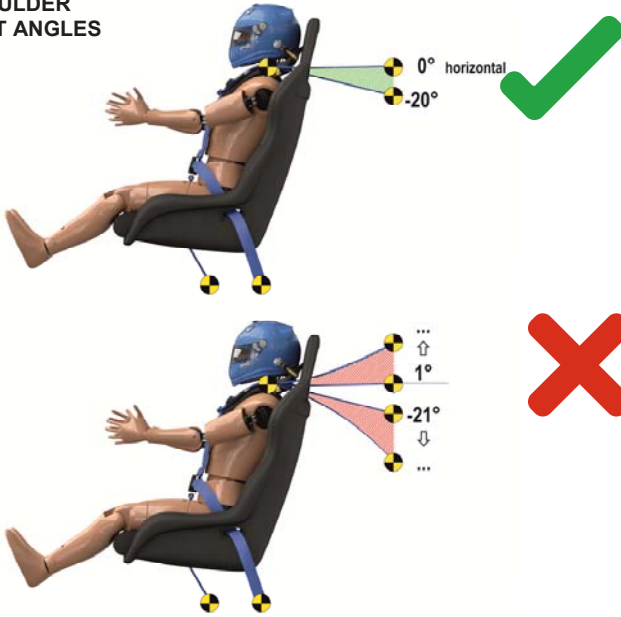

### SHOULDER BELT LENGTHS

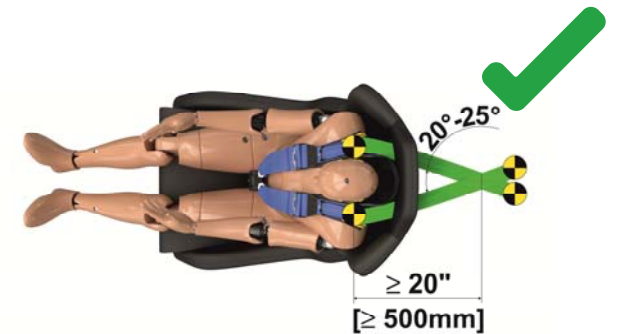
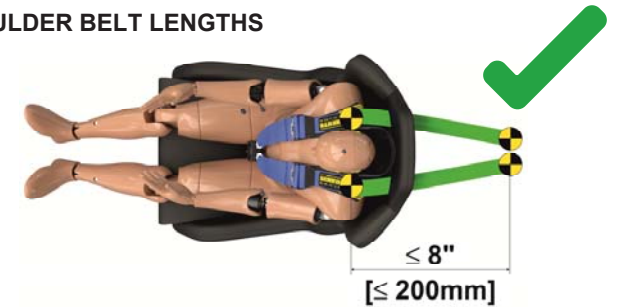

# ! WARNING

### Risk of severe injury or death!

- Always mount shoulder belts as short as possible to the mounting point. 6" [150 mm] or less is ideal.
- Do not exceed a mounting distance of 8" [200 mm] from the back of the user's seat without mounting and installing the shoulder belts as instructed below.
- If the mounting distance must exceed 8" [200 mm], mount the shoulder belts crossing at least 20" [500 mm] behind the driver's seat at an angle of 20°-25°.
- Maintain a shoulder belt angle of 0° to 20° DOWNWARD from the top of the FHR with a clear path through the seat to the shoulder mounting points. Optimum angle is 10° downward.
- NEVER angle the shoulder belts from the FHR at an upward angle to a mounting point.
- NEVER mount the shoulder belts through seat belt shoulder openings and directly down to the floor behind the seat, without passing over a harness bar at the proper angle.
- NEVER use sternum straps in combination with the FHR.
- Refer to your harness belt installation instructions for further details.

Improper mounting may severely compromise the effective performance of the FHR and safety harness may result in severe injury or death.

# SAFETY INSTRUCTIONS

Shorter shoulder belts / mounting points are better!  
Target ≤ 8" [200 mm] from back of seat.

**Routing of 2" [50mm] webbing**

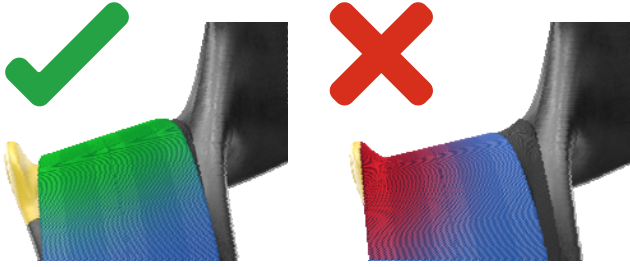

**Routing of 3" [75mm] webbing**

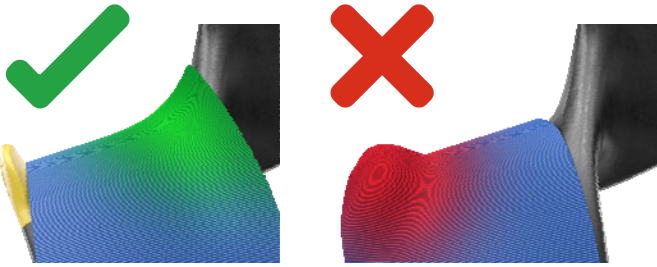

**FHR TETHERS**

WARNING

**Risk of severe injury or death!**  
 Use **ONLY** original SCHROTH parts to attach the tether system. Use **ONLY** original SCHROTH FHR tethers. Check the FHR tethers and helmet clips prior to each event / use.

**ANCHOR INSTALLATION INSTRUCTIONS**

**Helmet / Post Anchor Assembly**

**Twist Anchor Assembly**

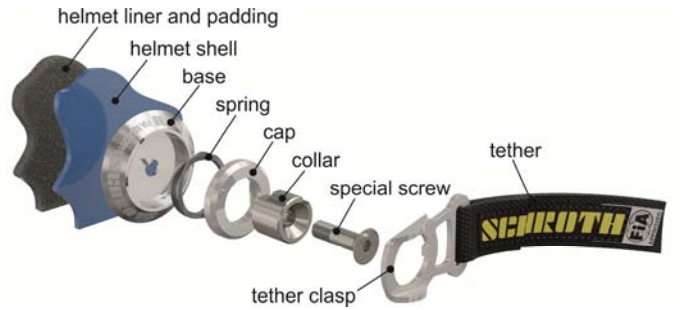
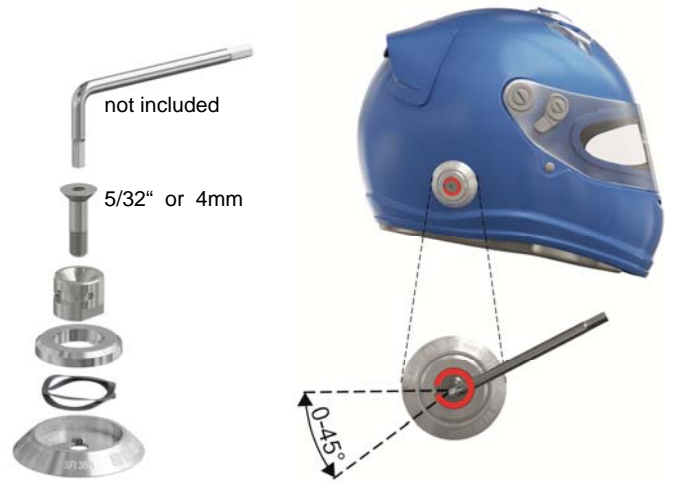

**Clip for right side of helmet**

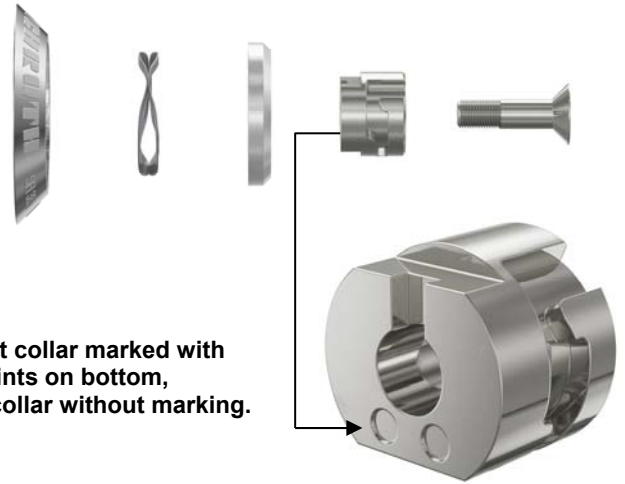

**Clip for left side of helmet**





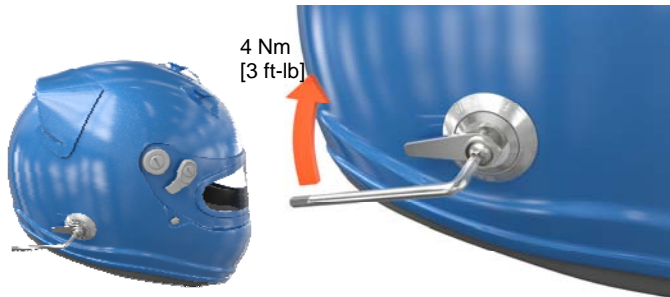
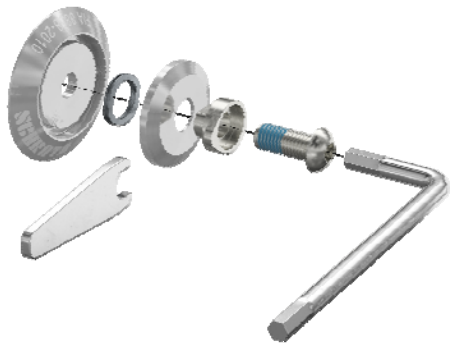

**FHR helmets with factory inserts (M6)**

Installation of Twist Anchors into Helmets with Bonded-in Threaded M6 Anchor Terminals

**SAH2010, SA2015, FIA 8859, FIA 8860 or FIA 8858 Helmets with bonded-in threaded M6 anchor terminals**

You may use one of the helmets marked as certified to the standards listed above for FHR head and neck restraint system use. These helmets have bonded-in threaded M6 terminals or nut-washers [see figure A], making FHR anchor installation easy.

# ! WARNING

**Risk of serious injury or death!**  
**Use only original SCHROTH FHR specific parts, including hardware and screws.**

Bonded-in threaded M6 anchor terminal on sides of helmet



# ! WARNING

**Risk of severe injury or death!**  
**THREADLOCKER – All FHR Device anchors are supplied with screws coated with a dry threadlocker compound. Threadlocker is to be used one time only.**

**Use the screws with threadlocker provided when assembling FHR helmet anchors.**  
**Failure to use original FHR screws with threadlocker may result in the twist anchors becoming loose.**

**Approval stickers - FHR helmets with factory inserts (M6)**



Snell SAH2010 decal located inside helmet

Bonded-in terminal on side of helmet

Helmet Compatible with Frontal Head Restraint Systems according to FIA Standard 8858-2010	
Manufacturer Name: Name of Manufacturer	
Serial N°: xxx xxx	Model Name
Model Size : XS	Date of Manufacture: JAN 2013

In compliance with: FIA Standard 8860-2010	
Manufacturer Name: Name of Manufacturer	
Serial N°: xxx xxx	Model Name
Homologation N° : AH.XXX.XX-X	Date of Manufacture: JAN 2013      Size: XS

In compliance with: FIA Standard 8859-2015	
Manufacturer Name: Name of Manufacturer	
Serial N°: xxx xxx	Model Name
Homologation N° : PH.XXX.XX-X	Date of Manufacture: JAN 2015      Size: XS

**FHR Clip FIA 8858-2002**

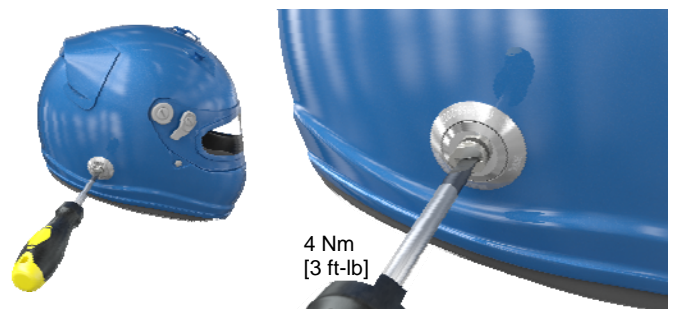
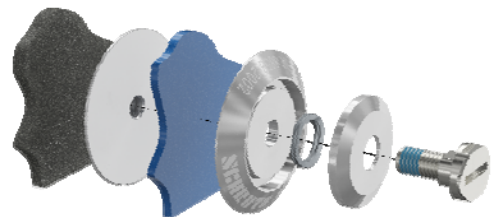

## Installation of post anchors into pre-drilled helmets without M6 terminals (SA2010)



figure B



figure C

- 1) Gently pry the helmet liner away from the shell using a thin, blunt instrument [see figure B]. Insert the nut-washer inside the helmet against the shell using a wrench.
- 2) Align the base, spring, cap and collar with the hole, engaging the notch in the underside of the cap with the nib on the inside of the base. Insert the special screw through the assembly into the M6 nut-washer.
- 3) Hand tighten until snug with the tether clasp indexing slot in the twist anchor collar facing rearward on the helmet.
- 4) Use a 7/16" [11 mm] wrench to hold the nut-washer inside of helmet in position and tighten the screw from the outside [see figure C] with a 5/32" [4 mm] hexagon socket screw key a 1/4 turn beyond snug [approximately 3ft-lb (4Nm) of torque] while holding the desired orientation of the twist anchor collar.

**! WARNING**

**Risk of serious injury or death!**  
Use only original SCHROTH specific hardware and screws.  
Use of unapproved parts may result in severe injury or death.

**! WARNING**

**Risk of injury or death!**  
Use care not to damage the helmet shell or EPS liner when inserting the nut-washer into the helmet.  
Damage to the EPS liner reduce the overall protection level of the helmet and cause serious injury or death.

**NOTICE**

SCHROTH does not recommend using helmets without pre-drilled holes.  
REFER TO YOUR SANCTIONING RULES FOR HELMET INSTALLATION.

## Frequently Asked Questions

### *What type of shoulder belts work best with a FHR Device?*

Any SFI or FIA approved harness system [e.g. SCHROTH] works with the FHR Device. 5-point, 6-point and 7-point belts with two inch [50mm] or three inch [75mm] wide shoulder belts are all fine to use with the FHR. Only approved 4-point belts with SCHROTH asm Systems should be used with a FHR system. Please ask SCHROTH for clarification on which models may be used. Do not use Sternum Straps with your FHR Device.

### *I race on a short track at relatively low speeds. Do I need a FHR Device?*

Yes. Serious head and neck injuries happen at impact speeds as low as 35 mph [56 kph]. On short tracks with tight turns it is easy to be "Q-balled" almost straight into the wall.

### *Can I share a FHR Device?*

Provided that you are of similar physical size and shape to your partner, chances are good that you can share a FHR Device. Always use original SCHROTH FHR Device helmet anchors and hardware.

### *I have an unusual race car. Do you make a FHR Device that will fit?*

Yes. The FHR Device can be worn in virtually any vehicle (not just cars) that uses two FIA or SFI shoulder belts as part of the driver restraint harness.

### *How do I care for my FHR Device?*

FHR Devices need almost no maintenance but should be kept clean and dry. To protect them, FHR Devices should be stored out of direct sunlight. They may be cleaned with soapy warm water but avoid solvent-based cleaners. Ensure rubber top surfaces stay clean and free of wear. Tethers should be replaced every 5 years or sooner if wear is observed. Check tethers and helmet clips prior to each event/use.

### *How long is the SFI certifications acceptable?*

Different race series may have different rules regarding age of certifications. As of June 2012, SFI 38.1 requires recertifying your FHR every 5 years.

### Have another question?

eMail us directly at [germany@schroth.com](mailto:germany@schroth.com) or visit [www.schroth.com](http://www.schroth.com)

