

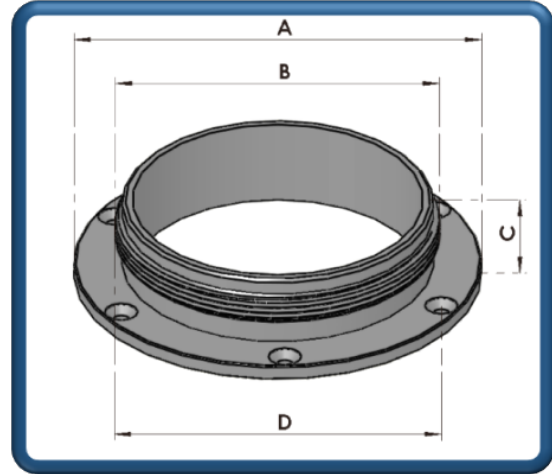

Classic 350

Classic 3.50" 6 Hole Flange.
Part Number: FL-AG-001 (CF350)



Specifications:

Options:
Fixing Arrangement:
Applications:
Compatibilities:

Finish:
Weight:
Supplied With:

N/A
6 x M5 CSK Bolts
Fuel, Oil & Water Tanks
Compatible with Add Blue
Operation Temperature -40°C to +80°C
Anodised Silver +AA6 BS EN ISO 7599
60.0 grams
Flange
Screw Pack (CSK Screws, Washers, Nyloc Nuts)
Gasket

Materials:

Flange:
Screw Pack:
Gasket:

Aluminium Alloy 6082/T6
A2 Type Stainless Steel
NBR Cork

Dimensions:

Outer Diameter A:
Thread Specifications B:
Height C:
PCD D:

126.0mm
3.5" x 11TPI BSP Thread
22.0mm
6 x M5 CKS Holes on a 114.3mm PCD

Optional('s):

Viton A Gasket
Classic 3.5" Cap

Fluid Containment – When It Matters

Tell: +4420 8594 7990 / Fax: +4420 8594 7989 / www.newton-equipment.com / info@newton-equipment.com
Registered in England. 6 Orwell Close/ Fairview Ind. Park/ Rainham/ Essex/ RM13 8UB